

# Island Memory Schematic Diagram

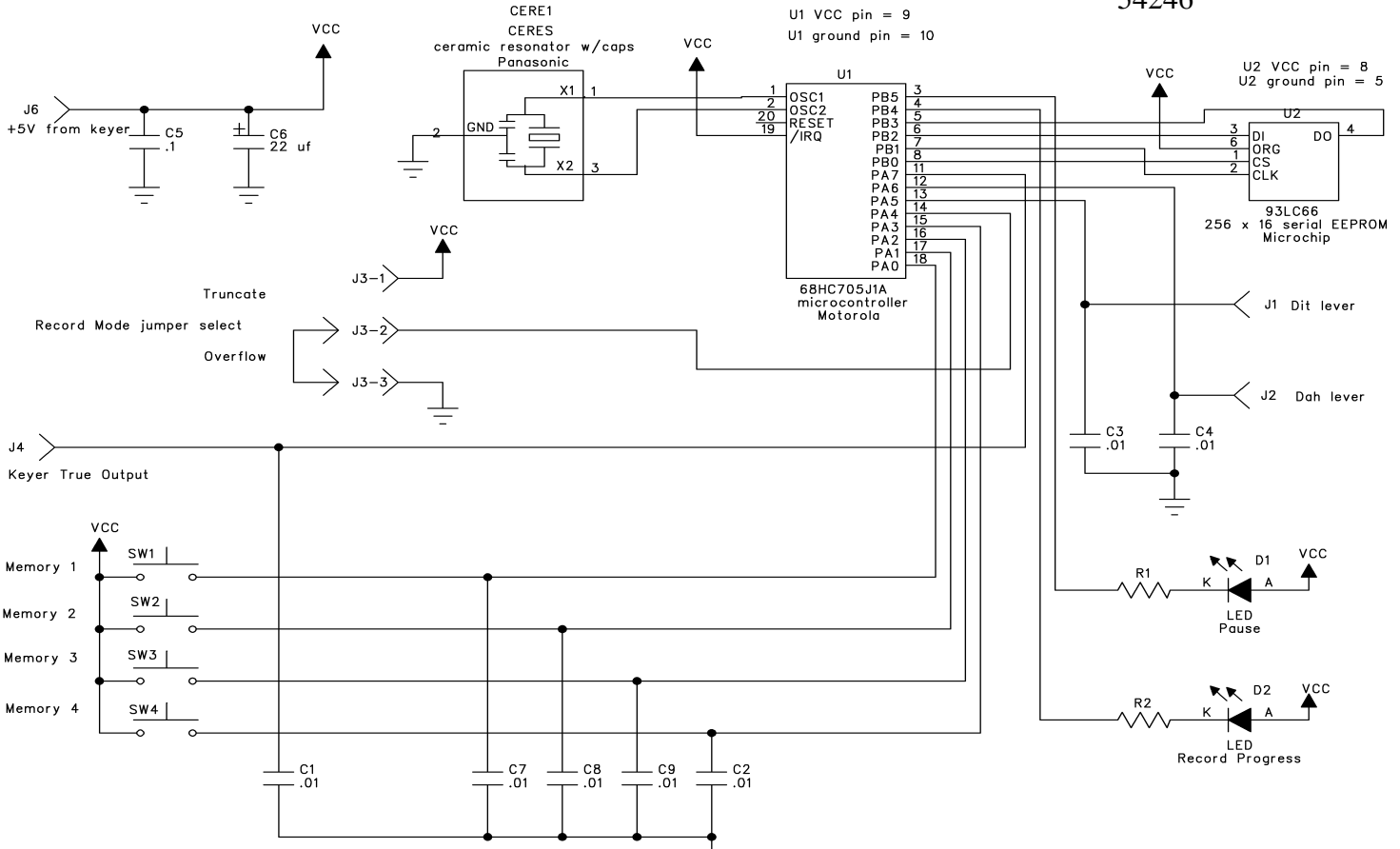

Jackson Harbor Press  
 RR1, Box 91C  
 Washington Island, WI  
 54246



Parts Placement Diagram  
 top view of circuit board

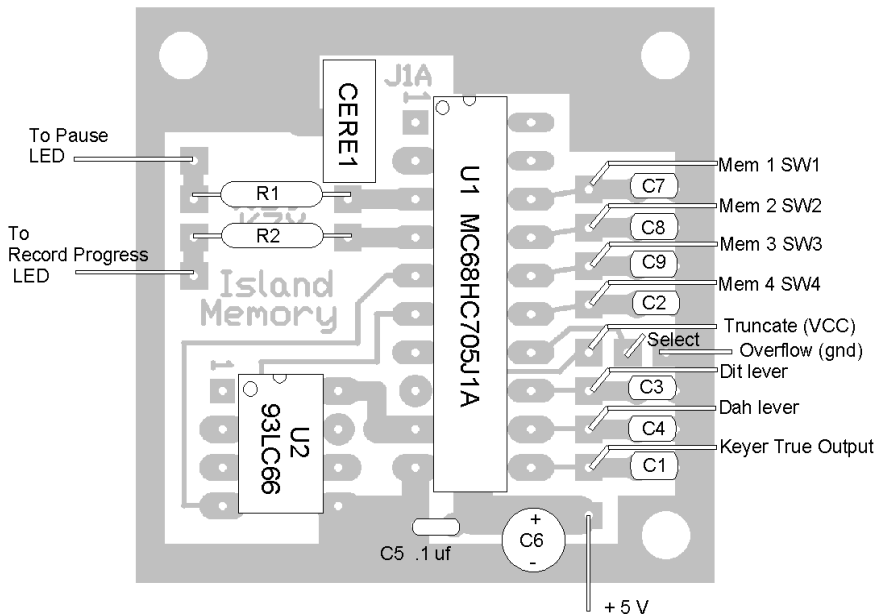

Bottom view of circuit board

