

PK-3 Schematic Diagram

Jackson Harbor Press
 RR1, Box 91C
 Washington Island, WI 54246
<http://jacksonharbor.home.att.net>
 jacksonharbor@att.net

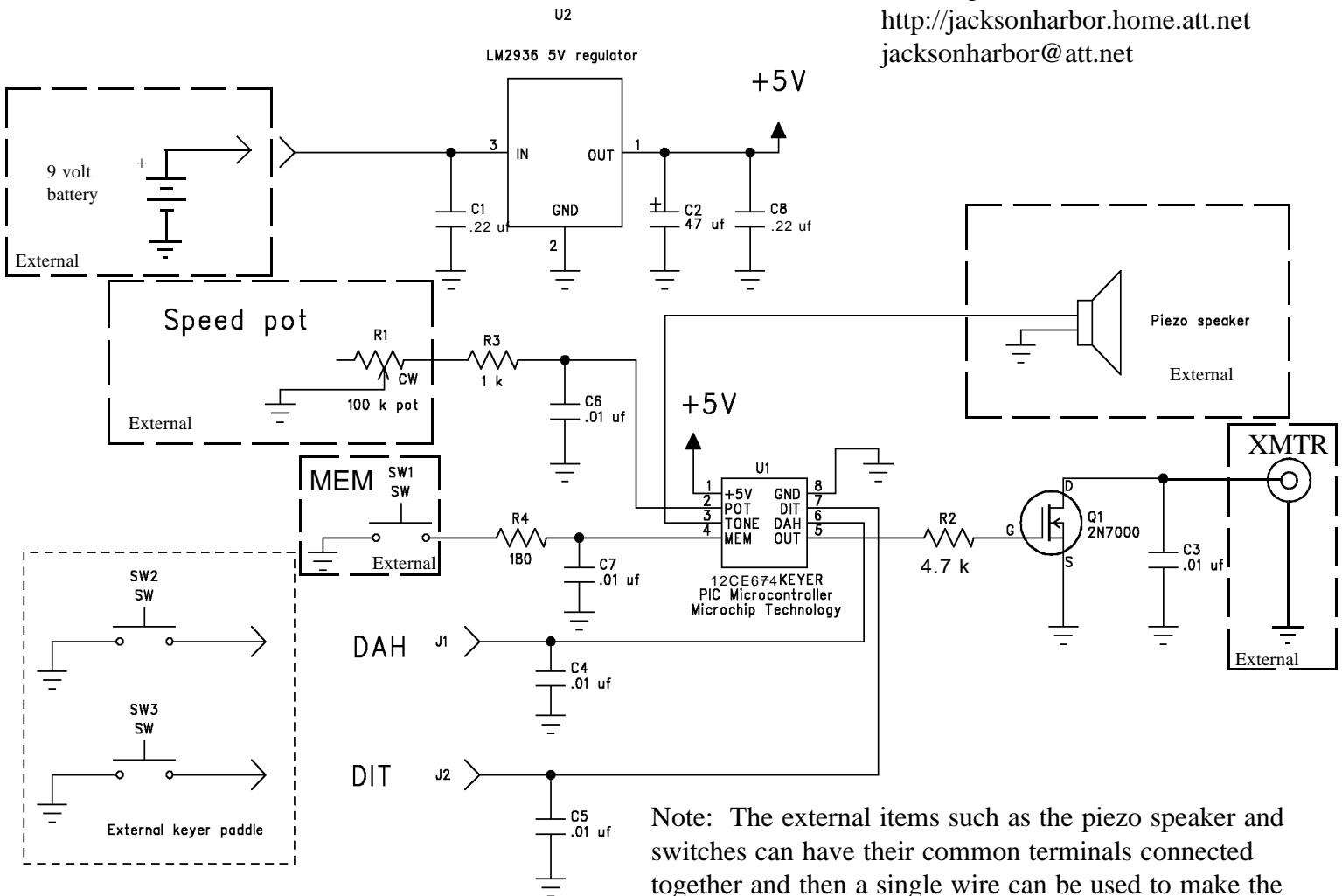

Note: The external items such as the piezo speaker and switches can have their common terminals connected together and then a single wire can be used to make the ground connection to the PK-3 circuit board. Ideally, the PK-3 will be housed in a metal case - the board mounted with a short metal standoff and star washers to insure a good electrical connection to ground.

Parts Placement Diagram Top View of Circuit Board

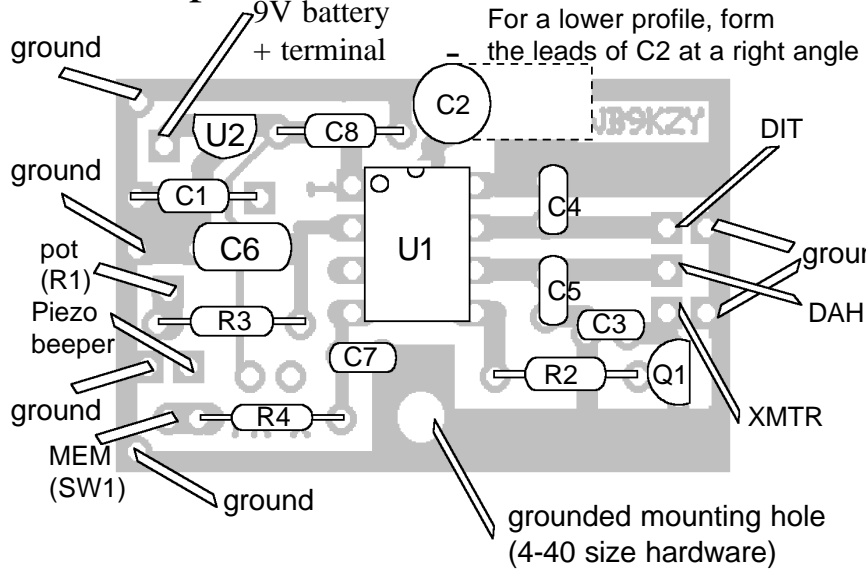

Bottom View of Circuit Board

